

**TECHNIQUE INFORMATION
DIESEL GENERATORS
GSG STAR DIESEL ENGINE POWERED**

GENSTAR
generator

STAR			GSG-75R	
Standby Power	kVA	75	Engine Speed	Power Factor
	kVA	60	1500 rpm	0,8 Cos Phi
Prime Power	kVA	68	Voltage	
	KW	54,5	400/230 V	

ENGINE

Brand		RICARDO
Model		ZH4105ZLD
Standby	kW	61,6
Prime	kW	56
Cylinder Displacement	lt.	3,9
Number of Cylinders		4 / In line
Bore x Stroke	mm x mm	105 x 115
Compression Ratio		17 : 1
Governer Type		Mechanic
Idle Speed	rpm	1500
Aspiration		Turbocharge, Intercooler
Injection Type		Direct Injection
Cooling System		Liquid Cooled
Fuel Consumption %100	lt/h	16,7
Fuel Consumption %75	lt/h	12,5
Fuel Consumption %50	lt/h	8,3
Oil Capacity	lt.	13
Cooling Liquid Capacity	lt.	17
Voltage	V	24
Battery Capacity	A	2 x 60

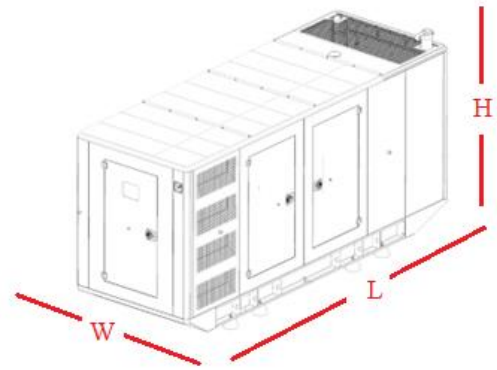

ALTERNATOR

Output Voltage	V	230/400
Frequency	HZ	50
Automatic Voltage Regulation	±%	0,5
Phase		3
Pole		4
Overload		1 Hour %110
Voltage Regulation	Cosq	1
Power Factor		0,8
Warning System		Self Alert
AVR Model		SX460
Total Harmonic Losing		≤%3
Connecting Type		Star
Protection Class		IP23
Isolation Class		H

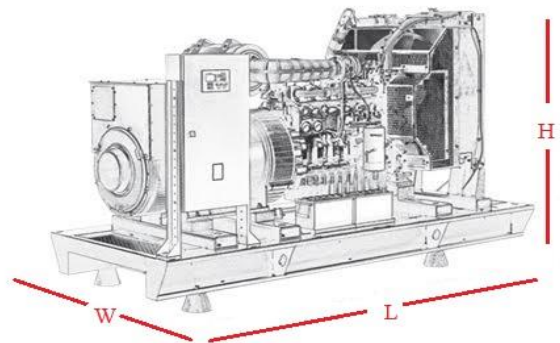

CANOPY VERSION			FUEL TANK CAPACITY (lt.)		OPEN VERSION			
Length (mm)	Width (mm)	Height(mm)	Dry Weight (kg)		Length (mm)	Width (mm)	Height(mm)	Dry Weight (kg)
1650	950	1660	TBA	160	2350	950	1400	TBA

OPTIONAL SPECIFICATION

- * 50°C cooland radiator
- * Flexible fuelpipes and oil drain valve
- * Engne jacket heater
- * 4 pole synchronous type self-excited brushless alternator
- * Battery and wres
- * Entegrated fuel tank
- * User and maintenance manual
- * Oil and antifreeze
- * Datakom D-300 controller
- * Battery charger
- * Electrcal circuit diagram
- * Comap AMF25 controller

TECHNIQUE INFORMATION
DIESEL GENERATORS
GSG STAR DIESEL ENGINE POWERED

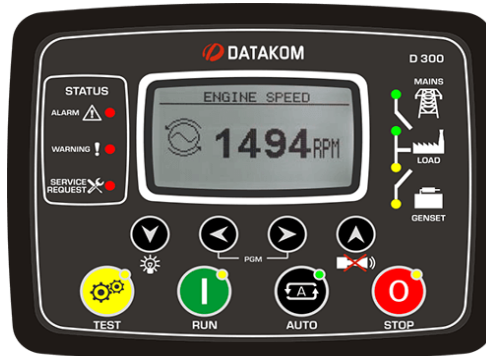

- * Diesel and gas genset support
- * 400Hz operation support
- * Downloadable languages
- * Harmonic analysis of V & I
- * Weekly operation schedule
- * Dual mutual standby with equal aging of gensets
- * Overload IDMT protection
- * Current unbalance protection
- * Fuel filling & fuel theft alarms
- * Battery back-up real time clock

- * Idle speed control
- * Contactor & MCB drive
- * Fuel filling counters
- * Fuel consumption counter
- * Automatic GSM geo-location
- * Reverse power protection
- * Free configuration program
- * Mobile genset support
- * 3 level configuration password
- * Ip65 rating with optional gasket



- * Full remote communications support (AirGate 2.0, WSV)
- * Internet access using Ethernet / 4G, Modbus TCP/RTU, SNMP v1/v2c
- * Active SMS and emails
- * Detailed history log with up to 350 records
- * Dual Mutual Standby application support
- * Remote display
- * User setpoints and protections
- * 5 languages in the controller & Translator functionality
- * User Access Management
- * Cyber security improvement
- * Alternative configurations
- * Multi-purpose schedulers
- * Modbus register mapping possibility

- * Stand-by and prime-power application in one unit
- * Backlit symbols
- * 8 binary outputs, 8 + 1 binary inputs, 4 analog inputs (U/I/R)
- * +5 V output reference for analog inputs
- * 2 high-current E-Stop binary outputs
- * USB Host
- * Inbuilt RS485
- * 2 slots for extension plug-in modules (Modbus, Internet, SMS, inputs/outputs)
- * Extension CAN modules
- * ECU support (Tier 4 Final, Stage V)
- * RTC with battery back-up (full calendar)
- * Power over USB for controller configuration
- * Zero power mode
- * True RMS measurement
- * In-built PLC, complemented with a PLC monitoring tool in IntelliConfig
- * Load shedding, dummy load management
- * User buttons
- * Geofencing based on GPS position
- * Available also in low temperature version (Order code:)