

**TECHNIQUE INFORMATION
DIESEL GENERATORS
GSG ALFA DIESEL ENGINE POWERED**



ALFA			GSG - C580	
Standby Power	kVA	580	Engine Speed	Power Factor
	kW	464	1500 rpm	0,8 Cos Phi
Prime Power	kVA	530	Voltage	
	kW	424	400 / 230 V	

ENGINE

FUEL CONSUMPTION (lt/h)

Brand		CUMMINS	%110 ESP	92
Power PRP	kW	463	%100 PRP	82
Model		QSZ13-G10	%75 PRP	60
N° of Cylinders / Valves		6	%50 PRP	41
Engine Type		4	(The specific gravity is 0.84 and the fuel is considered to be BS2869, Class A2.)	
Displacement	lt	13		
Aspiration		Turbocharger and Aftercooler System		
Bore x Stroke	mm	130x163		
Compression Ratio		17		
Air Filter		Heavy Duty		
Cooling Method		Water Cooled (water + %50 antifreeze)		
Total Coolant Capacity	lt	77,1		
Governor Type		Electronic PGI (CAN J1939)		
Electrical System		24VDC		
Battery Charger Current		80		
Oil Capacity	lt	75,3		
Exhaust Gas Temp.	[L/s]	1217		
Air Flow PRP	[C]	≤520		
Cooling Air Flow PRP	[L/s]	497		
Starter Power	[m3/s]	10,3		
Starter Power	(kW)	TBA		
Standard Battery Voltage		24 VDC		
Standard Battery Capacity		2x105Ah		
Standard Battery Type		Maintenance-Free Lead Acid		

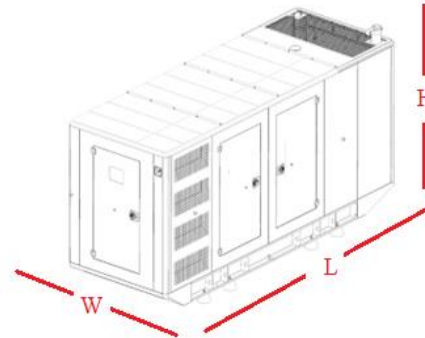

ALTERNATOR

Brand		STAMFORD
Model		S5L1D-D
Voltage		400 /230 VAC
Number of Phase		3
Power Factor		0,8
Number of Poles		4
Connection Type		Star
Bearing		Single
Insulation Class		H
Protection Class		IP 23
Winding		2/3
Control System		Self Excited
Voltage Regulator		Electronic AVR
Efficiency 4/4 400VAC 50Hz	(cosφ=1)	95,5
Voltage Regulation		±%1
THD		<%5
Apparent Power [kVA] Prime 400VAC 50Hz		550
	125°C/40°C	

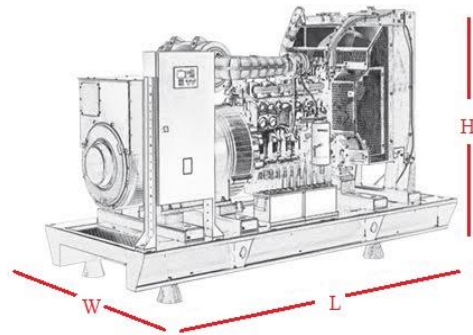

OPEN VERSION					CANOPY VERSION			
Width(mm)	Length(mm)	Height(mm)	Dry Weight (kg)	Fuel Tank Capacity (lt.)	Width(mm)	Length(mm)	Height(mm)	Dry Weight (kg)
1650	3980	2197	TBA	1200	1710	5000	2555	TBA

**TECHNIQUE INFORMATION
DIESEL GENERATORS
GSG ALFA DIESEL ENGINE POWERED**



- * Diesel and gas genset support
- * 400Hz operation support
- * Downloadable languages
- * Harmonic analysis of V & I
- * Weekly operation schedule
- * Dual mutual standby with equal aging of gensets
- * Overload IDMT protection
- * Current unbalance protection
- * Fuel filling & fuel theft alarms
- * Battery back-up real time clock

- * Idle speed control
- * Contactor & MCB drive
- * Fuel filling counters
- * Fuel consumption counter
- * Automatic GSM geo-location
- * Reverse power protection
- * Free configuration program
- * Mobile genset support
- * 3 level configuration password
- * IP65 rating with optional gasket

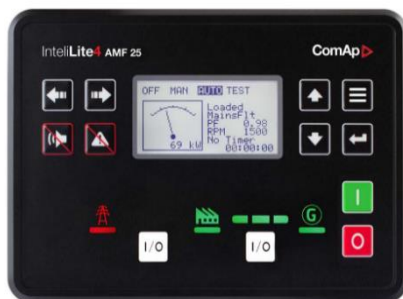

- * Full remote communications support (AirGate 2.0, WSV)
- * Internet access using Ethernet / 4G, Modbus TCP/RTU
SNMP v1/v2c
- * Active SMS and emails
- * Detailed history log with up to 350 records
- * Dual Mutual Standby application support
- * Remote display
- * User setpoints and protections
- * 5 languages in the controller & Translator functionality
- * User Access Management
- * Cyber security improvement
- * Alternative configurations
- * Multi-purpose schedulers
- * Modbus register mapping possibility

- * Stand-by and prime-power application in one unit
 - * Backlit symbols
 - * 8 binary outputs, 8 + 1 binary inputs, 4 analog inputs (U/I/R)
 - * +5 V output reference for analog inputs
 - * 2 high-current E-Stop binary outputs
 - * USB Host
 - * Inbuilt RS485
 - * 2 slots for extension plug-in modules (Modbus, Internet, SMS, inputs/outputs)
 - * Extension CAN modules
 - * ECU support (Tier 4 Final, Stage V)
 - * RTC with battery back-up (full calendar)
 - * Power over USB for controller configuration
 - * Zero power mode
 - * True RMS measurement
 - * In-built PLC, complemented with a PLC monitoring tool in IntelliConfig
 - * Load shedding, dummy load management
- User buttons
- * User buttons
 - * Geofencing based on GPS position
 - * Available also in low temperature version (Order code: