

**TECHNIQUE INFORMATION**  
**DIESEL GENERATORS**  
**GSG ALFA DIESEL ENGINE POWERED**



ALFA			GSG - P1125	
<b>Standby Power</b>	kVA	<b>1125</b>	<b>Engine Speed</b>	<b>Power Factor</b>
	kW	<b>900</b>	1500 rpm	0,8 Cos Phi
<b>Prime Power</b>	kVA	<b>1020</b>	<b>Voltage</b>	
	kW	<b>816</b>	400 / 230 V	

**ENGINE**

**FUEL CONSUMPTION (lt/h)**

Brand		PERKINS	%110 ESP	240
Power PRP	kW	861	%100 PRP	215
Model		4008-TAG2A	%75 PRP	162
N° of Cylinders / Valves		8/32	%50 PRP	111
Engine Type		4	(The specific gravity is 0.84 and the fuel is considered to be BS2869, Class A2.)	
Displacement	lt	30.56		
Aspiration		Turbocharged - Air to air cooled		
Bore x Stroke	mm	160x190		
Compression Ratio		13.6:1		
Air Filter		Heavy Duty		
Cooling Method		Water Cooled (water + %50 antifreeze)		
Total Coolant Capacity	lt	149		
Governor Type		Electronic		
Electrical System		24VDC		
Battery Charger Current		55A		
Oil Capacity	lt	153		
Exhaust Gas Flow PRP	[m3 / min]	200		
Exhaust Gas Temp.	[°C]	438		
Air Flow PRP	[m3/min]	75		
Cooling Air Flow PRP	[m3/min]	22.5		
Starter Power	(kW)	8,5		
Standard Battery Voltage	[V]	24VDC		
Standard Battery Capacity		4x105Ah		
Standard Battery Type		Maintenance-Free Lead Acid		

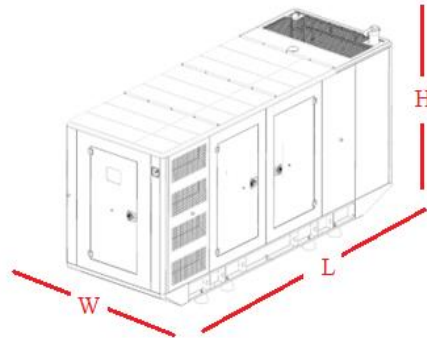

**ALTERNATOR**

Brand		LINZ
Model		PRO40S B/4
Voltage		400 /230 VAC
Number of Phase		3
Power Factor		0.8
Number of Poles		4
Connection Type		Star
Bearing		Single
Insulation Class		H
Protection Class		IP 23
Winding		2/3
Control System		Self Excited
Voltage Regulator		Electronic AVR
Efficiency 4/4 400VAC 50Hz	(cosφ=1)	96.6
Voltage Regulation		±%1
THD		<%3
Apparent Power [kVA] Prime 400VAC 50Hz		1050
	125°C/40°C	

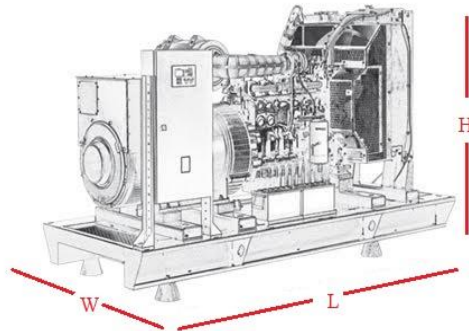

OPEN VERSION					CANOPY VERSION			
Width(mm)	Length(mm)	Height(mm)	Dry Weight (kg)	Fuel Tank Capacity (lt.)	Width(mm)	Length(mm)	Height(mm)	Dry Weight (kg)
2050	4500	2580	7585	1500	2370	5960	2611*	9235

**TECHNIQUE INFORMATION  
DIESEL GENERATORS  
GSG ALFA DIESEL ENGINE POWERED**



- \* Diesel and gas genset support
- \* 400Hz operation support
- \* Downloadable languages
- \* Harmonic analysis of V & I
- \* Weekly operation schedule
- \* Dual mutual standby with equal aging of gensets
- \* Overload IDMT protection
- \* Current unbalance protection
- \* Fuel filling & fuel theft alarms
- \* Battery back-up real time clock

- \* Idle speed control
- \* Contactor & MCB drive
- \* Fuel filling counters
- \* Fuel consumption counter
- \* Automatic GSM geo-location
- \* Reverse power protection
- \* Free configuration program
- \* Mobile genset support
- \* 3 level configuration password
- \* Ip65 rating with optional gasket



- \* Full remote communications support (AirGate 2.0, WSV)
- \* Internet access using Ethernet / 4G, Modbus TCP/RTU  
SNMP v1/v2c
- \* Active SMS and emails
- \* Detailed history log with up to 350 records
- \* Dual Mutual Standby application support
- \* Remote display
- \* User setpoints and protections
- \* 5 languages in the controller & Translator functionality
- \* User Access Management
- \* Cyber security improvement
- \* Alternative configurations
- \* Multi-purpose schedulers
- \* Modbus register mapping possibility

- \* Stand-by and prime-power application in one unit
  - \* Backlit symbols
  - \* 8 binary outputs, 8 + 1 binary inputs, 4 analog inputs (U/I/R)
  - \* +5 V output reference for analog inputs
  - \* 2 high-current E-Stop binary outputs
  - \* USB Host
  - \* Inbuilt RS485
  - \* 2 slots for extension plug-in modules (Modbus, Internet, SMS, inputs/outputs)
  - \* Extension CAN modules
  - \* ECU support (Tier 4 Final, Stage V)
  - \* RTC with battery back-up (full calendar)
  - \* Power over USB for controller configuration
  - \* Zero power mode
  - \* True RMS measurement
  - \* In-built PLC, complemented with a PLC monitoring tool in IntelliConfig
  - \* Load shedding, dummy load management
- User buttons
- \* User buttons
  - \* Geofencing based on GPS position
  - \* Available also in low temperature version (Order code: