

TECHNIQUE INFORMATION
DIESEL GENERATORS
GSG ALFA DIESEL ENGINE POWERED



ALFA		GSG - P1770	
-------------	--	--------------------	--

Standby Power	kVA	1770	Engine Speed	Power Factor
	kW	1416	1500 rpm	0,8 Cos Phi

Prime Power	kVA	1650	Voltage	
	KW	1320	400 / 230 V	

ENGINE

Brand	PERKINS
Power PRP	1440 kW
Model	4012-46TAG3A
N° of Cylinders / Valves	12/48
Engine Type	4
Displacement	45,8 lt
Aspiration	Turbocharged - Air to air cooled
Bore x Stroke	160x190 mm
Compression Ratio	13:1
Air Filter	Heavy Duty
Cooling Method	Water Cooled (water + %50 antifreeze)
Total Coolant Capacity	210 lt
Governor Type	Electronic
Electrical System	24VDC
Battery Charger Current	40A
Oil Capacity	177 lt
Exhaust Gas Flow PRP	350 [m3 / min]
Exhaust Gas Temp.	180 [°C]
Air Flow PRP	125 [m3/min]
Cooling Air Flow PRP	37 [m3/min]
Starter Power	16,4 (kW)
Standard Battery Voltage	24VDC [V]
Standard Battery Capacity	4x150Ah
Standard Battery Type	Maintenance-Free Lead Acid

FUEL CONSUMPTION (lt/h)

%110 ESP	405
%100 PRP	370
%75 PRP	275
%50 PRP	187

(The specific gravity is 0.84 and the fuel is considered to be BS2869, Class A2.)

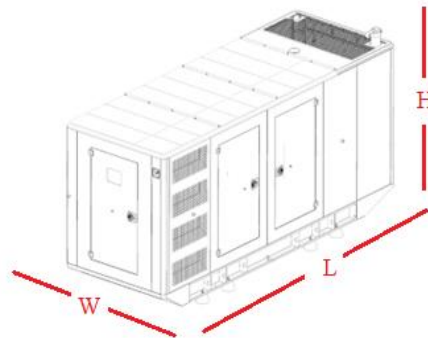

ALTERNATOR

Brand	LINZ
Model	S7L1D-E4
Voltage	400 /230 VAC
Number of Phase	3
Power Factor	0.8
Number of Poles	4
Connection Type	Star
Bearing	Single
Insulation Class	H
Protection Class	IP 23
Winding	2/3
Control System	Self Excited
Voltage Regulator	Electronic AVR
Efficiency 4/4 400VAC 50Hz	96.9 (cosφ=1)
Voltage Regulation	±%1
THD	<%5
Apparent Power [kVA] Prime 400VAC 50Hz 125°C/40°C	1750

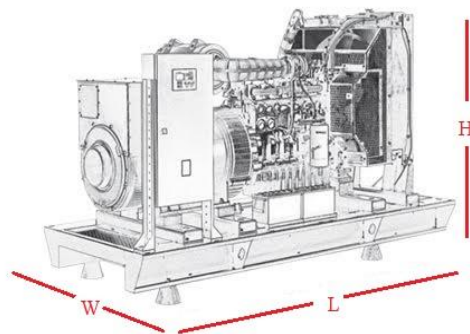

OPEN VERSION					CANOPY VERSION			
Width(mm)	Length(mm)	Height(mm)	Dry Weight (kg)	Fuel Tank Capacity (lt.)	Width(mm)	Length(mm)	Height(mm)	Dry Weight (kg)
2260	5060	2420	TBA	3000	2440	9126	3000*	TBA

**TECHNIQUE INFORMATION
DIESEL GENERATORS
GSG ALFA DIESEL ENGINE POWERED**

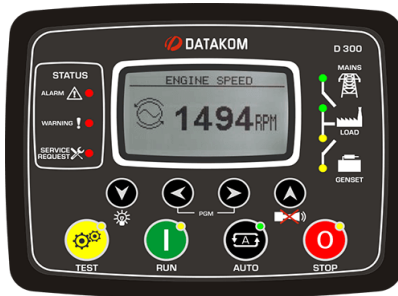

- * Diesel and gas genset support
- * 400Hz operation support
- * Downloadable languages
- * Harmonic analysis of V & I
- * Weekly operation schedule
- * Dual mutual standby with equal aging of gensets
- * Overload IDMT protection
- * Current unbalance protection
- * Fuel filling & fuel theft alarms
- * Battery back-up real time clock

- * Idle speed control
- * Contactor & MCB drive
- * Fuel filling counters
- * Fuel consumption counter
- * Automatic GSM geo-location
- * Reverse power protection
- * Free configuration program
- * Mobile genset support
- * 3 level configuration password
- * Ip65 rating with optional gasket



- * Full remote communications support (AirGate 2.0, WSV)
- * Internet access using Ethernet / 4G, Modbus TCP/RTU
SNMP v1/v2c
- * Active SMS and emails
- * Detailed history log with up to 350 records
- * Dual Mutual Standby application support
- * Remote display
- * User setpoints and protections
- * 5 languages in the controller & Translator functionality
- * User Access Management
- * Cyber security improvement
- * Alternative configurations
- * Multi-purpose schedulers
- * Modbus register mapping possibility

- * Stand-by and prime-power application in one unit
 - * Backlit symbols
 - * 8 binary outputs, 8 + 1 binary inputs, 4 analog inputs (U/I/R)
 - * +5 V output reference for analog inputs
 - * 2 high-current E-Stop binary outputs
 - * USB Host
 - * Inbuilt RS485
 - * 2 slots for extension plug-in modules (Modbus, Internet,
SMS, inputs/outputs)
 - * Extension CAN modules
 - * ECU support (Tier 4 Final, Stage V)
 - * RTC with battery back-up (full calendar)
 - * Power over USB for controller configuration
 - * Zero power mode
 - * True RMS measurement
 - * In-built PLC, complemented with a PLC monitoring tool in
InteliConfig
 - * Load shedding, dummy load management
- User buttons
- * User buttons
 - * Geofencing based on GPS position
 - * Available also in low temperature version (Order code: