

**TECHNIQUE INFORMATION**  
**DIESEL GENERATORS**  
**GSG ALFA DIESEL ENGINE POWERED**



ALFA			GSG - P2500	
<b>Standby Power</b>	kVA	<b>2500</b>	<b>Engine Speed</b>	<b>Power Factor</b>
	kW	<b>2000</b>	1500 rpm	0,8 Cos Phi
<b>Prime Power</b>	kVA	<b>2250</b>	<b>Voltage</b>	
	KW	<b>1850</b>	400 / 230 V	

**ENGINE**

**FUEL CONSUMPTION (lt/h)**

Brand		PERKINS
Power PRP	kW	1875
Model		4016-61TRG3
N° of Cylinders / Valves		16/64
Engine Type		4
Displacement	lt	61.123
Aspiration		Turbocharged - Air to water charge cooled
Bore x Stroke	mm	160x190
Compression Ratio		13:1
Air Filter		Heavy Duty
Cooling Method		Water Cooled (water + %50 antifreeze)
Total Coolant Capacity	lt	500
Governor Type		Electronic
Electrical System		24VDC
Battery Charger Current		55A
Oil Capacity	lt	213
Exhaust Gas Flow PRP	[m3 / min]	525
Exhaust Gas Temp.	[°C]	560
Air Flow PRP	[m3/min]	160
Cooling Air Flow PRP	[m3/min]	3320
Starter Power	(kW)	16.4
Standard Battery Voltage	[V]	24VDC
Standard Battery Capacity		4x150Ah
Standard Battery Type		Maintenance-Free Lead Acid

%110 ESP	529
%100 PRP	470
%75 PRP	349
%50 PRP	246

(The specific gravity is 0.84 and the fuel is considered to be BS2869, Class A2.)

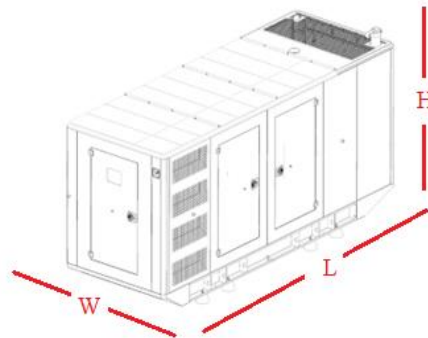

**ALTERNATOR**

Brand		STAMFORD
Model		PI734H
Voltage		400 /230 VAC
Number of Phase		3
Power Factor		0.8
Number of Poles		4
Connection Type		Star
Bearing		Single
Insulation Class		H
Protection Class		IP 23
Winding		2/3
Control System		Self Excited
Voltage Regulator		Electronic AVR
Efficiency 4/4 400VAC 50Hz	(cosφ=1)	97
Voltage Regulation		±%1
THD		<%5
Apparent Power [kVA] Prime 400VAC 50Hz 125°C/40°C		2325

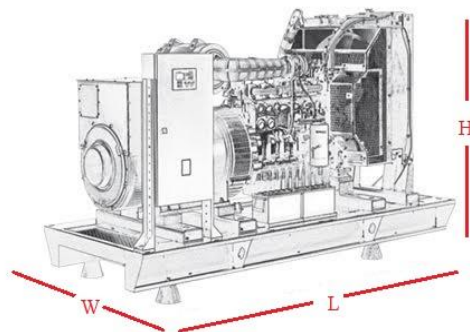

OPEN VERSION					CANOPY VERSION			
Width(mm)	Length(mm)	Height(mm)	Dry Weight (kg)	Fuel Tank Capacity (lt.)	Width(mm)	Length(mm)	Height(mm)	Dry Weight (kg)
2260	5060	2420	TBA	3000	2440	9126	3000*	TBA



- \* Diesel and gas genset support
- \* 400Hz operaton support
- \* Downloadable languages
- \* Harmonic analysis of V & I
- \* Weekly operaton schedule
- \* Dual mutual standby wth equal agng of gensets
- \* Overload IDMT protecton
- \* Current unbalance protecton
- \* Fuel filling & fuel theft alarms
- \* Battery back-up real tme clock

- \* Idle speed control
- \* Contactor & MCB drive
- \* Fuel filling counters
- \* Fuel consumption counter
- \* Automatic GSM geo-locaton
- \* Reverse power protecton
- \* Free configuraton program
- \* Mobile genset support
- \* 3 level configuraton password
- \* Ip65 ratng wth optional gasket



- \* Full remote communications support (AirGate 2.0, WSV)
- \* Internet access using Ethernet / 4G, Modbus TCP/RTU  
SNMP v1/v2c
- \* Active SMS and emails
- \* Detailed history log with up to 350 records
- \* Dual Mutual Standby application support
- \* Remote display
- \* User setpoints and protections
- \* 5 languages in the controller & Translator functionality
- \* User Access Management
- \* Cyber security improvement
- \* Alternative configurations
- \* Multi-purpose schedulers
- \* Modbus register mapping possibility

- \* Stand-by and prime-power application in one unit
- \* Backlit symbols
- \* 8 binary outputs, 8 + 1 binary inputs, 4 analog inputs (U/I/R)
- \* +5 V output reference for analog inputs
- \* 2 high-current E-Stop binary outputs
- \* USB Host
- \* Inbuild RS485
- \* 2 slots for extension plug-in modules (Modbus, Internet,  
SMS, inputs/outputs)
- \* Extension CAN modules
- \* ECU support (Tier 4 Final, Stage V)
- \* RTC with battery back-up (full calendar)
- \* Power over USB for controller configuration
- \* Zero power mode
- \* True RMS measurement
- \* In-built PLC, complemented with a PLC monitoring tool in  
InteliConfig
- \* Load shedding, dummy load management
- User buttons
  - \* User buttons
  - \* Geofencing based on GPS position
  - \* Available also in low temperature version (Order code: