

TECHNIQUE INFORMATION
DIESEL GENERATORS
GSG ALFA DIESEL ENGINE POWERED



ALFA			GSG - P450	
Standby Power	kVA	450	Engine Speed	Power Factor
	kW	360	1500 rpm	0,8 Cos Phi
Prime Power	kVA	400	Voltage	
	kW	320	400 / 230 V	

ENGINE

Brand		PERKINS
Power PRP	kW	349
Model		2206A-E13TAG3
N° of Cylinders / Valves		6/24
Engine Type		4
Displacement	lt	12.5
Aspiration		Turbocharged - Air to air cooled
Bore x Stroke	mm	130x157
Compression Ratio		16.3:1
Air Filter		Heavy Duty
Cooling Method		Water Cooled (water + %50 antifreeze)
Total Coolant Capacity	lt	51.4
Governor Type		ECM (Engine Control Modul)
Electrical System		24VDC
Battery Charger Current		70A
Oil Capacity	lt	40
Exhaust Gas Flow PRP	[m3 / min]	64,6
Exhaust Gas Temp.	[°C]	630
Air Flow PRP	[m3/min]	24.3
Cooling Air Flow PRP	[m3/min]	654
Starter Power	(kW)	7,8 kW
Standard Battery Voltage	[V]	24VDC
Standard Battery Capacity		2x105Ah
Standard Battery Type		Maintenance-Free Lead Acid

FUEL CONSUMPTION (lt/h)

%110 ESP	90
%100 PRP	81
%75 PRP	62
%50 PRP	42

(The specific gravity is 0.84 and the fuel is considered to be BS2869, Class A2.)

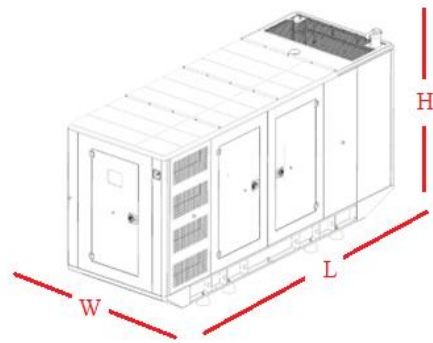

ALTERNATOR

Brand		LINZ
Model		PRO28L G/4
Voltage		400 /230 VAC
Number of Phase		3
Power Factor		0.8
Number of Poles		4
Connection Type		Star
Bearing		Single
Insulation Class		H
Protection Class		IP 23
Winding		5/6
Control System		Self Excited
Voltage Regulator		Electronic AVR
Efficiency 4/4 400VAC 50Hz	(cosφ=1)	95.2
Voltage Regulation		±%1
THD		<%3.3
Apparent Power [kVA] Prime 400VAC 50Hz		400
	125°C/40°C	

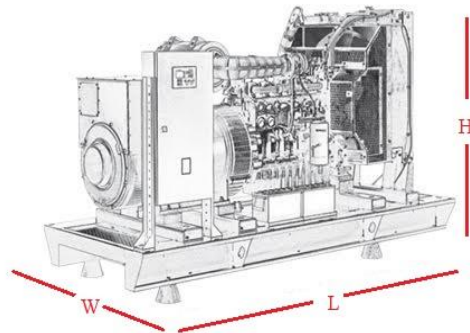

OPEN VERSION					CANOPY VERSION			
Width(mm)	Length(mm)	Height(mm)	Dry Weight (kg)	Fuel Tank Capacity (lt.)	Width(mm)	Length(mm)	Height(mm)	Dry Weight (kg)
1650	3750	1942	2915	1130	1710	4710	2560	3767

**TECHNIQUE INFORMATION
DIESEL GENERATORS
GSG ALFA DIESEL ENGINE POWERED**



- * Diesel and gas genset support
- * 400Hz operation support
- * Downloadable languages
- * Harmonic analysis of V & I
- * Weekly operation schedule
- * Dual mutual standby with equal aging of gensets
- * Overload IDMT protection
- * Current unbalance protection
- * Fuel filling & fuel theft alarms
- * Battery back-up real time clock

- * Idle speed control
- * Contactor & MCB drive
- * Fuel filling counters
- * Fuel consumption counter
- * Automatic GSM geo-location
- * Reverse power protection
- * Free configuration program
- * Mobile genset support
- * 3 level configuration password
- * Ip65 rating with optional gasket



- * Full remote communications support (AirGate 2.0, WSV)
- * Internet access using Ethernet / 4G, Modbus TCP/RTU, SNMP v1/v2c
- * Active SMS and emails
- * Detailed history log with up to 350 records
- * Dual Mutual Standby application support
- * Remote display
- * User setpoints and protections
- * 5 languages in the controller & Translator functionality
- * User Access Management
- * Cyber security improvement
- * Alternative configurations
- * Multi-purpose schedulers
- * Modbus register mapping possibility

- * Stand-by and prime-power application in one unit
- * Backlit symbols
- * 8 binary outputs, 8 + 1 binary inputs, 4 analog inputs (U/I/R)
- * +5 V output reference for analog inputs
- * 2 high-current E-Stop binary outputs
- * USB Host
- * Inbuilt RS485
- * 2 slots for extension plug-in modules (Modbus, Internet, SMS, inputs/outputs)
- * Extension CAN modules
- * ECU support (Tier 4 Final, Stage V)
- * RTC with battery back-up (full calendar)
- * Power over USB for controller configuration
- * Zero power mode
- * True RMS measurement
- * In-built PLC, complemented with a PLC monitoring tool in IntelliConfig
- * Load shedding, dummy load management
- User buttons
 - * User buttons
 - * Geofencing based on GPS position
 - * Available also in low temperature version (Order code: