

TECHNIQUE INFORMATION
DIESEL GENERATORS
GSG STAR DIESEL ENGINE POWERED



STAR			GSG - S110	
Standby Power	kVA	110	Engine Speed	Power Factor
	kW	88	1500 rpm	0,8 Cos Phi
Prime Power	kVA	100	Voltage	
	KW	80	400 / 230 V	

ENGINE

FUEL CONSUMPTION (lt/h)

Brand	SDEC	%110 ESP	27,7
Power PRP	105	%100 PRP	25
Model	SC4H160D2	%75 PRP	16,7
N° of Cylinders / Valves	4/16	%50 PRP	12,8
Engine Type	4 Stroke	(The specific gravity is 0.84 and the fuel is considered to be BS2869, Class A2.)	
Displacement	4,3		
Aspiration	Turbocharged - Intercooled		
Bore x Stroke	105x124		
Compression Ratio	16:1		
Air Filter	Replaceable Element		
Cooling Method	Water Cooled (water + %50 antifreeze)		
Total Coolant Capacity	19,3		
Governor Type	Electronic		
Electrical System	24VDC		
Battery Charger Current	55A		
Oil Capacity	13		
Exhaust Gas Flow PRP	16,3		
Exhaust Gas Temp.	600		
Air Flow PRP	7,39		
Cooling Air Flow PRP	185,4		
Starter Power	4,5		
Standard Battery Voltage	24VDC		
Standard Battery Capacity	2X60Ah		
Standard Battery Type	Maintenance-Free Lead Acid		

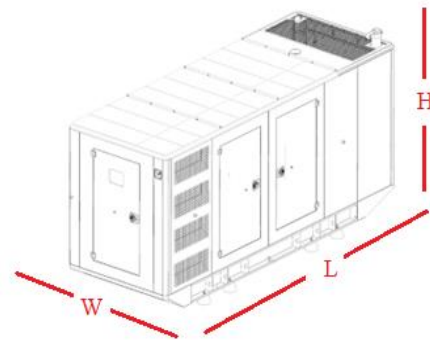

ALTERNATOR

Brand	NEKRA
Model	ARK 274C
Voltage	400/230 VAC
Number of Phase	3
Power Factor	0.8
Number of Poles	4
Connection Type	Star
Bearing	Single
Insulation Class	H
Protection Class	IP 23
Winding	2/3
Control System	Self Excited
Voltage Regulator	Electronic AVR
Efficiency 4/4 400VAC 50Hz	92,4
Voltage Regulation	+%1
THD	<%5
Apparent Power [kVA] Prime 400VAC 50Hz	100
125°C/40°C	

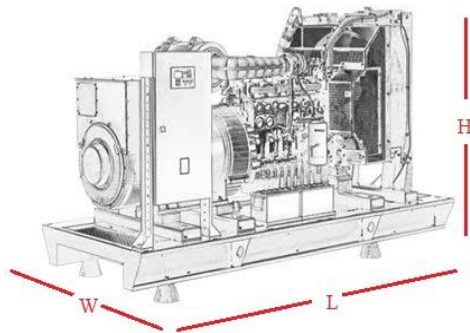

OPEN VERSION					CANOPY VERSION			
Width(mm)	Length(mm)	Height(mm)	Dry Weight (kg)	Fuel Tank Capacity (lt.)	Width(mm)	Length(mm)	Height(mm)	Dry Weight (kg)
1100	2150	1370	1169	174	1100	2880	1720	1540

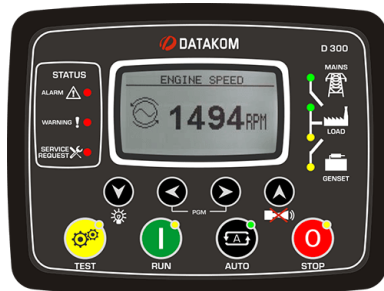

- * Diesel and gas genset support
- * 400Hz operation support
- * Downloadable languages
- * Harmonic analysis of V & I
- * Weekly operation schedule
- * Dual mutual standby with equal aging of gensets
- * Overload IDMT protection
- * Current unbalance protection
- * Fuel filling & fuel theft alarms
- * Battery back-up real time clock

- * Idle speed control
- * Contactor & MCB drive
- * Fuel filling counters
- * Fuel consumption counter
- * Automatic GSM geo-location
- * Reverse power protection
- * Free configuration program
- * Mobile genset support
- * 3 level configuration password
- * IP65 rating with optional gasket

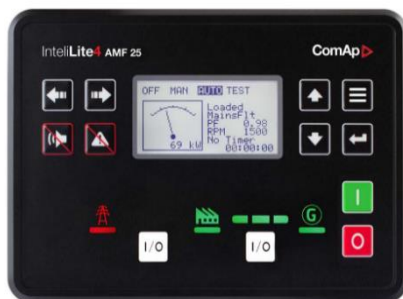

- * Full remote communications support (AirGate 2.0, WSV)
- * Internet access using Ethernet / 4G, Modbus TCP/RTU
SNMP v1/v2c
- * Active SMS and emails
- * Detailed history log with up to 350 records
- * Dual Mutual Standby application support
- * Remote display
- * User setpoints and protections
- * 5 languages in the controller & Translator functionality
- * User Access Management
- * Cyber security improvement
- * Alternative configurations
- * Multi-purpose schedulers
- * Modbus register mapping possibility

- * Stand-by and prime-power application in one unit
 - * Backlit symbols
 - * 8 binary outputs, 8 + 1 binary inputs, 4 analog inputs (U/I/R)
 - * +5 V output reference for analog inputs
 - * 2 high-current E-Stop binary outputs
 - * USB Host
 - * Inbuilt RS485
 - * 2 slots for extension plug-in modules (Modbus, Internet, SMS, inputs/outputs)
 - * Extension CAN modules
 - * ECU support (Tier 4 Final, Stage V)
 - * RTC with battery back-up (full calendar)
 - * Power over USB for controller configuration
 - * Zero power mode
 - * True RMS measurement
 - * In-built PLC, complemented with a PLC monitoring tool in IntelliConfig
 - * Load shedding, dummy load management
- User buttons
- * User buttons
 - * Geofencing based on GPS position
 - * Available also in low temperature version (Order code: