

TECHNIQUE INFORMATION
DIESEL GENERATORS
GSG STAR DIESEL ENGINE POWERED



| STAR | | | GSG - S194 | |
|----------------------|-----|--------------|---------------------|---------------------|
| Standby Power | kVA | 194 | Engine Speed | Power Factor |
| | kW | 155,2 | 1500 rpm | 0,8 Cos Phi |
| Prime Power | kVA | 180 | Voltage | |
| | KW | 144 | 400 / 230 V | |

ENGINE

FUEL CONSUMPTION (lt/h)

| | | | |
|---------------------------|---------------------------------------|---|------|
| Brand | SDEC | %110 ESP | 39,9 |
| Power PRP | kW 154 | %100 PRP | 36 |
| Model | SC7H230D2 | %75 PRP | 26,8 |
| N° of Cylinders / Valves | 6/24 | %50 PRP | 17,8 |
| Engine Type | 4 Stroke | (The specific gravity is 0.84 and the fuel is considered to be BS2869, Class A2.) | |
| Displacement | lt 6,44 | | |
| Aspiration | Turbocharged - Intercooled | | |
| Bore x Stroke | mm 105x124 | | |
| Compression Ratio | 16:1 | | |
| Air Filter | Replaceable Element | | |
| Cooling Method | Water Cooled (water + %50 antifreeze) | | |
| Total Coolant Capacity | lt 28,6 | | |
| Governor Type | Electronic | | |
| Electrical System | 24VDC | | |
| Battery Charger Current | 55A | | |
| Oil Capacity | lt 17,5 | | |
| Exhaust Gas Flow PRP | [m3/min] 27,2 | | |
| Exhaust Gas Temp. | [°C] 600 | | |
| Air Flow PRP | [m3/min] 12,2 | | |
| Cooling Air Flow PRP | [m3/min] 271,8 | | |
| Starter Power | (kW) 6 | | |
| Standard Battery Voltage | [V] 24VDC | | |
| Standard Battery Capacity | 2X75 | | |
| Standard Battery Type | Maintenance-Free Lead Acid | | |

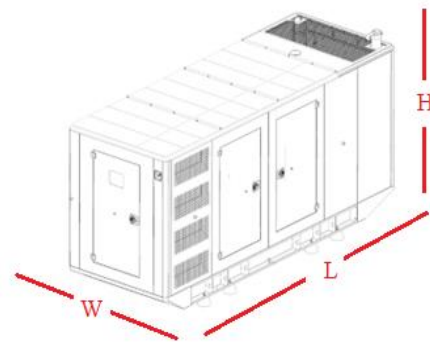

ALTERNATOR

| | |
|--|----------------|
| Brand | NEKRA |
| Model | ARK 274G |
| Voltage | 400/230 VAC |
| Number of Phase | 3 |
| Power Factor | 0,8 |
| Number of Poles | 4 |
| Connection Type | Star |
| Bearing | Single |
| Insulation Class | H |
| Protection Class | IP 23 |
| Winding | 2/3 |
| Control System | Self Excited |
| Voltage Regulator | Electronic AVR |
| Efficiency 4/4 400VAC 50Hz | (cosφ=1) 94 |
| Voltage Regulation | +%1 |
| THD | <%5 |
| Apparent Power [kVA] Prime 400VAC 50Hz | 180 |
| | 125°C/40°C |

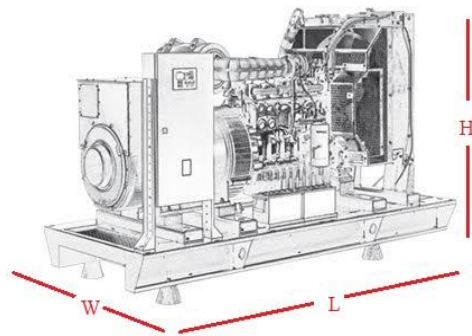

| OPEN VERSION | | | | | CANOPY VERSION | | | |
|--------------|------------|------------|-----------------|--------------------------|----------------|------------|------------|-----------------|
| Width(mm) | Length(mm) | Height(mm) | Dry Weight (kg) | Fuel Tank Capacity (lt.) | Width(mm) | Length(mm) | Height(mm) | Dry Weight (kg) |
| 1100 | 2650 | 1550 | 1639 | 294 | 1100 | 3440 | 1950 | 2100 |



- * Diesel and gas genset support
- * 400Hz operation support
- * Downloadable languages
- * Harmonic analysis of V & I
- * Weekly operation schedule
- * Dual mutual standby with equal aging of gensets
- * Overload IDMT protection
- * Current unbalance protection
- * Fuel filling & fuel theft alarms
- * Battery back-up real time clock

- * Idle speed control
- * Contactor & MCB drive
- * Fuel filling counters
- * Fuel consumption counter
- * Automatic GSM geo-location
- * Reverse power protection
- * Free configuration program
- * Mobile genset support
- * 3 level configuration password
- * IP65 rating with optional gasket

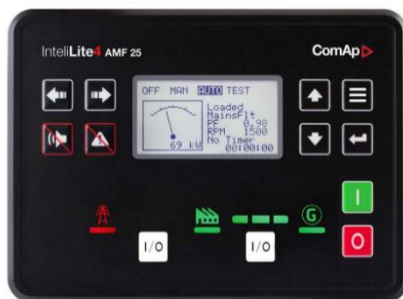

- * Full remote communications support (AirGate 2.0, WSV)
- * Internet access using Ethernet / 4G, Modbus TCP/RTU, SNMP v1/v2c
- * Active SMS and emails
- * Detailed history log with up to 350 records
- * Dual Mutual Standby application support
- * Remote display
- * User setpoints and protections
- * 5 languages in the controller & Translator functionality
- * User Access Management
- * Cyber security improvement
- * Alternative configurations
- * Multi-purpose schedulers
- * Modbus register mapping possibility

- * Stand-by and prime-power application in one unit
 - * Backlit symbols
 - * 8 binary outputs, 8 + 1 binary inputs, 4 analog inputs (U/I/R)
 - * +5 V output reference for analog inputs
 - * 2 high-current E-Stop binary outputs
 - * USB Host
 - * Inbuilt RS485
 - * 2 slots for extension plug-in modules (Modbus, Internet, SMS, inputs/outputs)
 - * Extension CAN modules
 - * ECU support (Tier 4 Final, Stage V)
 - * RTC with battery back-up (full calendar)
 - * Power over USB for controller configuration
 - * Zero power mode
 - * True RMS measurement
 - * In-built PLC, complemented with a PLC monitoring tool in IntelliConfig
 - * Load shedding, dummy load management
- User buttons
- * User buttons
 - * Geofencing based on GPS position
 - * Available also in low temperature version (Order code: