

TECHNIQUE INFORMATION
DIESEL GENERATORS
GSG STAR DIESEL ENGINE POWERED



STAR		GSG - S265	
-------------	--	-------------------	--

Standby Power	kVA	265	Engine Speed	Power Factor
	kW	212	1500 rpm	0,8 Cos Phi
Prime Power	kVA	240	Voltage	
	KW	192	400 / 230 V	

ENGINE

FUEL CONSUMPTION (lt/h)

Brand	SDEC	%110 ESP	55,6
Power PRP	kW 208	%100 PRP	50,6
Model	SC9D310D2	%75 PRP	38,2
N° of Cylinders / Valves	6/12	%50 PRP	26,3
Engine Type	4 Stroke	(The specific gravity is 0.84 and the fuel is considered to be BS2869, Class A2.)	
Displacement	lt 8,82		
Aspiration	Turbocharged - Intercooled		
Bore x Stroke	mm 114X144		
Compression Ratio	18:1		
Air Filter	Replaceable Element		
Cooling Method	Water Cooled (water + %50 antifreeze)		
Total Coolant Capacity	lt 40		
Governor Type	Electronic		
Electrical System	24VDC		
Battery Charger Current	55A		
Oil Capacity	lt 19		
Exhaust Gas Flow PRP	[m3/min] 35,9		
Exhaust Gas Temp.	[°C] 600		
Air Flow PRP	[m3/min] 16,4		
Cooling Air Flow PRP	[m3/min] 373,8		
Starter Power	(kW) 7,5		
Standard Battery Voltage	[V] 24VDC		
Standard Battery Capacity	2X75Ah		
Standard Battery Type	Maintenance-Free Lead Acid		

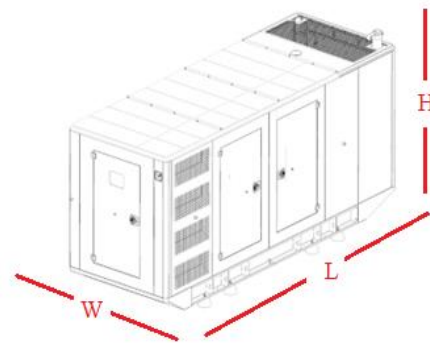

ALTERNATOR

Brand	NEKRA
Model	ARK 274K
Voltage	400/230 VAC
Number of Phase	3
Power Factor	0,8
Number of Poles	4
Connection Type	Star
Bearing	Single
Insulation Class	H
Protection Class	IP 23
Winding	2/3
Control System	Self Excited
Voltage Regulator	Electronic AVR
Efficiency 4/4 400VAC 50Hz	(cosφ=1) 94,4
Voltage Regulation	+%1
THD	<%5
Apparent Power [kVA] Prime 400VAC 50Hz	250
	125°C/40°C

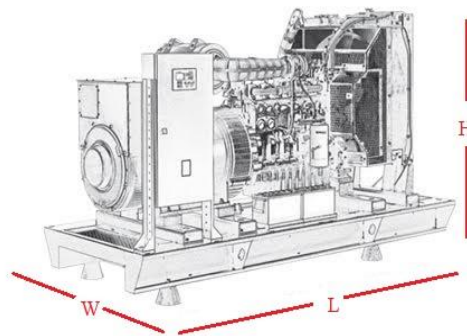

OPEN VERSION					CANOPY VERSION			
Width(mm)	Length(mm)	Height(mm)	Dry Weight (kg)	Fuel Tank Capacity (lt.)	Width(mm)	Length(mm)	Height(mm)	Dry Weight (kg)
1200	3200	1742	1926	460	1260	4094	2063	2450

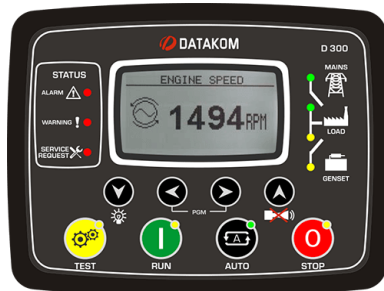

- * Diesel and gas genset support
- * 400Hz operation support
- * Downloadable languages
- * Harmonic analysis of V & I
- * Weekly operation schedule
- * Dual mutual standby with equal aging of gensets
- * Overload IDMT protection
- * Current unbalance protection
- * Fuel filling & fuel theft alarms
- * Battery back-up real time clock

- * Idle speed control
- * Contactor & MCB drive
- * Fuel filling counters
- * Fuel consumption counter
- * Automatic GSM geo-location
- * Reverse power protection
- * Free configuration program
- * Mobile genset support
- * 3 level configuration password
- * IP65 rating with optional gasket

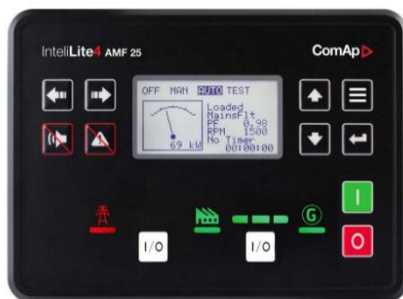

- * Full remote communications support (AirGate 2.0, WSV)
- * Internet access using Ethernet / 4G, Modbus TCP/RTU
SNMP v1/v2c
- * Active SMS and emails
- * Detailed history log with up to 350 records
- * Dual Mutual Standby application support
- * Remote display
- * User setpoints and protections
- * 5 languages in the controller & Translator functionality
- * User Access Management
- * Cyber security improvement
- * Alternative configurations
- * Multi-purpose schedulers
- * Modbus register mapping possibility

- * Stand-by and prime-power application in one unit
- * Backlit symbols
- * 8 binary outputs, 8 + 1 binary inputs, 4 analog inputs (U/I/R)
- * +5 V output reference for analog inputs
- * 2 high-current E-Stop binary outputs
- * USB Host
- * Inbuilt RS485
- * 2 slots for extension plug-in modules (Modbus, Internet, SMS, inputs/outputs)
- * Extension CAN modules
- * ECU support (Tier 4 Final, Stage V)
- * RTC with battery back-up (full calendar)
- * Power over USB for controller configuration
- * Zero power mode
- * True RMS measurement
- * In-built PLC, complemented with a PLC monitoring tool in IntelliConfig
- * Load shedding, dummy load management
- User buttons
- * User buttons
- * Geofencing based on GPS position
- * Available also in low temperature version (Order code: