

**TECHNIQUE INFORMATION  
DIESEL GENERATORS  
GSG STAR DIESEL ENGINE POWERED**



STAR			GSG - S440	
<b>Standby Power</b>	kVA	440	<b>Engine Speed</b>	<b>Power Factor</b>
	kW	352	1500 rpm	0,8 Cos Phi
<b>Prime Power</b>	kVA	400	<b>Voltage</b>	
	KW	320	400 / 230 V	

**ENGINE**

**FUEL CONSUMPTION (lt/h)**

Brand	SDEC	%110 ESP	90,3
Power PRP	kW 330	%100 PRP	81,2
Model	SC15G500D2	%75 PRP	59,8
N° of Cylinders / Valves	6/24	%50 PRP	41,1
Engine Type	4 Stroke	(The specific gravity is 0.84 and the fuel is considered to be BS2869, Class A2.)	
Displacement	lt 14,6		
Aspiration	Turbocharged - Intercooled		
Bore x Stroke	mm 135x165		
Compression Ratio	15,55:1		
Air Filter	Replaceable Element		
Cooling Method	Water Cooled (water + %50 antifreeze)		
Total Coolant Capacity	lt 80,5		
Governor Type	Electronic		
Electrical System	24VDC		
Battery Charger Current	55A		
Oil Capacity	lt 41		
Exhaust Gas Flow PRP	[m3/min] 50,5		
Exhaust Gas Temp.	[°C] 600		
Air Flow PRP	[m3/min] 19,8		
Cooling Air Flow PRP	[m3/min] 642,6		
Starter Power	(kW) 7,5		
Standard Battery Voltage	[V] 24VDC		
Standard Battery Capacity	2x105Ah		
Standard Battery Type	Maintenance-Free Lead Acid		

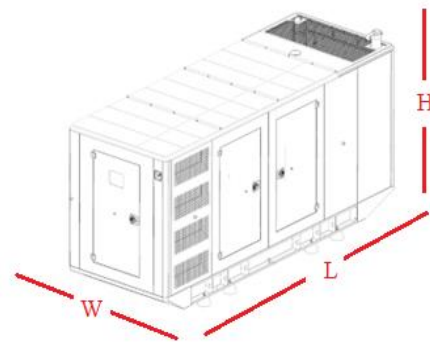

**ALTERNATOR**

Brand	NEKRA
Model	ARK 4FG
Voltage	400/230 VAC
Number of Phase	3
Power Factor	0,8
Number of Poles	4
Connection Type	Star
Bearing	Single
Insulation Class	H
Protection Class	IP 23
Winding	2/3
Control System	Self Excited
Voltage Regulator	Electronic AVR
Efficiency 4/4 400VAC 50Hz	(cosφ=1) 95,1
Voltage Regulation	+%1
THD	<%5
Apparent Power [kVA] Prime 400VAC 50Hz	400
	125°C/40°C

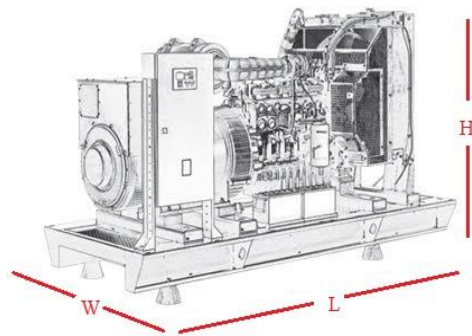

OPEN VERSION					CANOPY VERSION			
Width(mm)	Length(mm)	Height(mm)	Dry Weight (kg)	Fuel Tank Capacity (lt.)	Width(mm)	Length(mm)	Height(mm)	Dry Weight (kg)
1450	3450	1820	3207	780	1510	4370	2205	4059

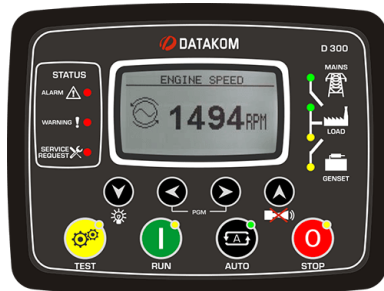

- \* Diesel and gas genset support
- \* 400Hz operation support
- \* Downloadable languages
- \* Harmonic analysis of V & I
- \* Weekly operation schedule
- \* Dual mutual standby with equal aging of gensets
- \* Overload IDMT protection
- \* Current unbalance protection
- \* Fuel filling & fuel theft alarms
- \* Battery back-up real time clock

- \* Idle speed control
- \* Contactor & MCB drive
- \* Fuel filling counters
- \* Fuel consumption counter
- \* Automatic GSM geo-location
- \* Reverse power protection
- \* Free configuration program
- \* Mobile genset support
- \* 3 level configuration password
- \* IP65 rating with optional gasket



- \* Full remote communications support (AirGate 2.0, WSV)
- \* Internet access using Ethernet / 4G, Modbus TCP/RTU, SNMP v1/v2c
- \* Active SMS and emails
- \* Detailed history log with up to 350 records
- \* Dual Mutual Standby application support
- \* Remote display
- \* User setpoints and protections
- \* 5 languages in the controller & Translator functionality
- \* User Access Management
- \* Cyber security improvement
- \* Alternative configurations
- \* Multi-purpose schedulers
- \* Modbus register mapping possibility

- \* Stand-by and prime-power application in one unit
  - \* Backlit symbols
  - \* 8 binary outputs, 8 + 1 binary inputs, 4 analog inputs (U/I/R)
  - \* +5 V output reference for analog inputs
  - \* 2 high-current E-Stop binary outputs
  - \* USB Host
  - \* Inbuilt RS485
  - \* 2 slots for extension plug-in modules (Modbus, Internet, SMS, inputs/outputs)
  - \* Extension CAN modules
  - \* ECU support (Tier 4 Final, Stage V)
  - \* RTC with battery back-up (full calendar)
  - \* Power over USB for controller configuration
  - \* Zero power mode
  - \* True RMS measurement
  - \* In-built PLC, complemented with a PLC monitoring tool in IntelliConfig
  - \* Load shedding, dummy load management
- User buttons
- \* User buttons
  - \* Geofencing based on GPS position
  - \* Available also in low temperature version (Order code: